

# DEADBOLTS

## DEADBOLTS ONLY THUMBTURN



Cod. CER-285 / CER-2854

Installation guide

Unscaled format

### HOW TO INSTALL YOUR SECURITY AUXILIARY EMBED LOCK

For single cylinder / For double cylinder

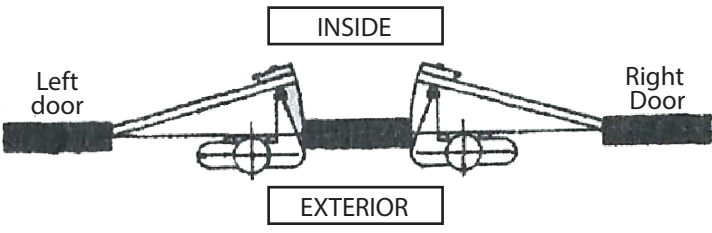
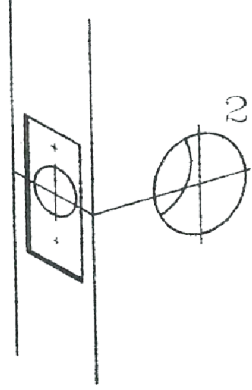
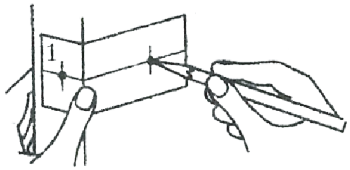
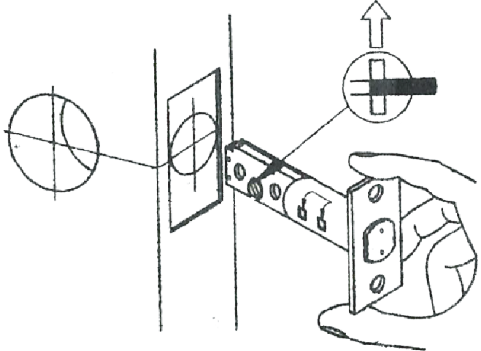
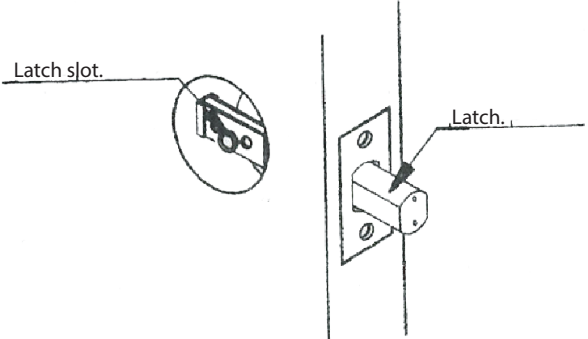
<b>1</b> <b>HOW TO DETERMINE THE DIRECTION OF THE DOOR</b>	<b>3</b> <b>DRILL THE GAPS</b>
	<p>Drill a 54mm hole centering at point 2 (2-1/8") Drill a 25mm hole centering at the point 1</p> 
<b>2</b> <b>MARK THE GAPS</b>	
<p>Select the height from the floor to install the lock. Fold the pattern along the dotted line. Mark pints 1 and 2 (2').</p> 	
<b>4</b> <b>INSTALL THE LATCH</b>	<b>5</b> <b>LATCH POSITION</b>
<p>Insert the latch through the 25mm hole. Mark the outline of the front. Make a 3mm deep box. Then secure the latch. Note: The arrow indicates the direction of installation.</p> 	<p>Indicate the installation process always with the handle outside the case as shown in the figure. Since otherwise the instructions of the numeral 6 are reversed.</p> 

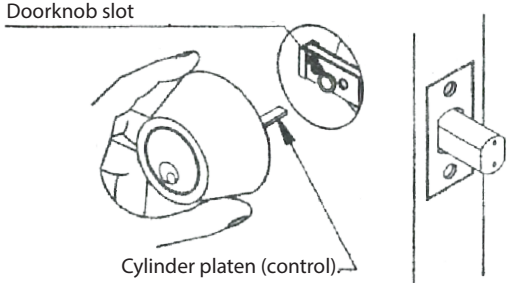
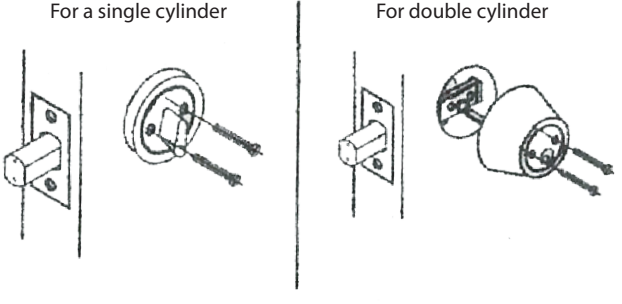
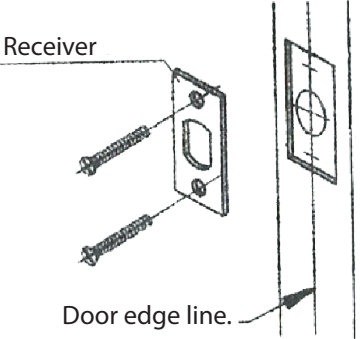
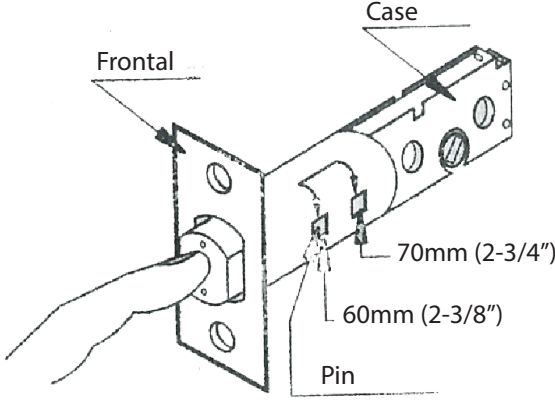
<p><b>6</b> <b>INSTALL EXTERIOR MECHANISM</b></p>	<p><b>7</b> <b>INSTALL THE LATCH</b></p>
<p>For right doors, take the outer cylinder with the platen (knob) facing you and turn it clockwise (right) until it stops and is horizontal. Then insert it through the slot in the latch. For left door, take the cylinder in the same direction, but turn the plate counterclockwise (left).</p> 	<p>For a single cylinder. Insert the screws and secure them. For double cylinder Position the cylinder platen (knob) vertically and insert it through the slot in the latch. Insert the screws and secure them</p> 
<p><b>8</b> <b>INSTALL THE RECEIVER</b></p>	<p><b>9</b> <b>ADJUSTABLE LATCH INSTRUCTIONS</b></p>
<p>Close the door and with the help of the latch mark its position in the door frame. Mark the center of the 25mm hole and the location of the screws. Make a 3mm deep box and then drill the 25mm hole. Then place the receiver and tighten.</p> 	<p>Hold the frontal and with the other hand turn the lock case 1/4 of turn, then retract or pull it according to the case until the pin is located again.</p> 

**INSTALLATION PATTERN**

