

CONCEALED HINGE

MINI-HINGE



Cod. C16A273 / C16B273 / C16C273

Installation guide

Product



Description

- Opening angle: 105°
- Bore depth: 3/8"
- Cup diameter: 1"
- Door thickness: 1/2"-7/8"
- Possible drilling distances on the door (K) : 1/8" - 1/4"
- For use on cabinet / closet doors

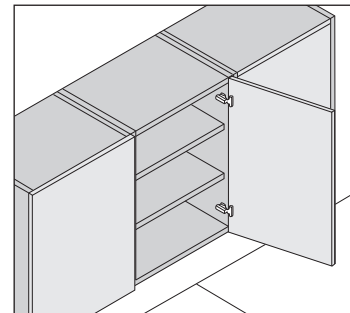

Space needed to open the door

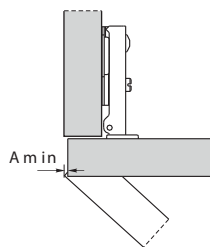

	T=	12	13	14	15	16	17	18	19	20	21	22
K=3	A=	0.5	0.8	1.1	1.4	1.9	2.6	3.4	4.2	5.1	6.0	6.9
K=4	A=	0.5	0.7	1.0	1.4	1.8	2.3	3.0	3.8	4.6	5.4	6.3
K=5	A=	0.5	0.7	1.0	1.3	1.7	2.2	2.8	3.4	4.2	5.0	5.8
K=6	A=	0.4	0.6	0.9	1.2	1.6	2.0	2.5	3.2	3.9	4.6	5.4
K=7	A=	0.4	0.6	0.9	1.2	1.5	1.9	2.4	2.9	3.6	4.3	5.0

- T=Door thickness
- K=Cup hole drilling distance from door edge

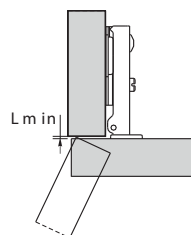

	T=	12	13	14	15	16	17	18	19	20	21	22
K=3	L=	0.0	0.0	0.0	0.0	0.0	0.1	0.1	0.3	0.5	0.6	0.8
K=4	L=	0.0	0.2	0.4	0.6	0.7	0.9	1.1	1.3	1.4	1.6	1.8
K=5	L=	1.0	1.2	1.4	1.6	1.7	1.9	2.1	2.2	2.4	2.6	2.8
K=6	L=	2.0	2.2	2.4	2.5	2.7	2.9	3.1	3.2	3.4	3.6	3.8
K=7	L=	3.0	3.2	3.4	3.5	3.7	3.9	4.0	4.2	4.4	4.6	4.7

- The above values are calculated on the assumption that the doors have square edge.
- They are reduced if the doors have radiused edges.

Projection of the door

Projection of the door from the cabinet side at the max opening. The figures are based on a straight arm hinge, H=0mm thickness of mounting plate and K, value =3mm.

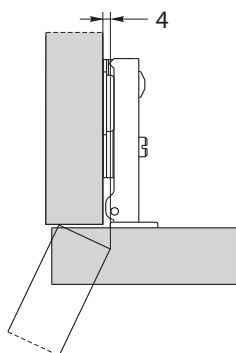

"C" value

With this formula you can obtain the max. Thickness of the moulded door that can be opened without touching adjacent carcass sides, doors or walls, whilst bearing in mind the above L-K-T values.

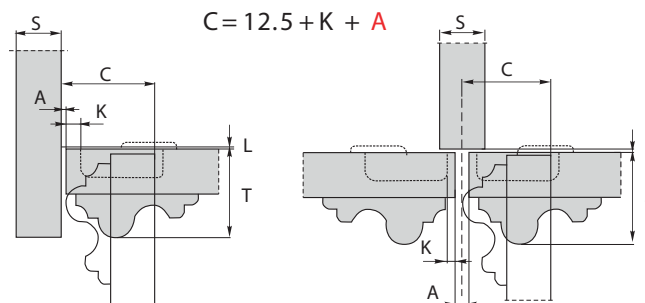

Ø 26mm Hinge cup types

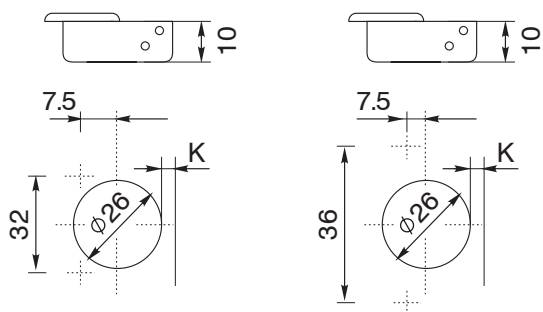

Use these formulas to determine the type of hinge arm, the drilling distance "K" and the height of the mounting plate "H" which is necessary to solve each application problem.

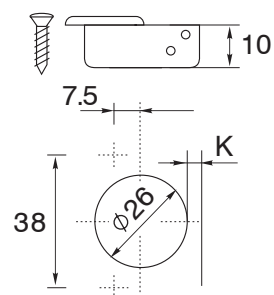

Concealed mini hinge 105°

Full overlay C=0

Cod. C16A273

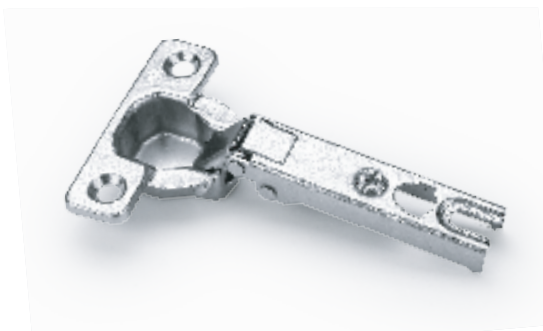

$$H = 12.5 + K - (D)$$

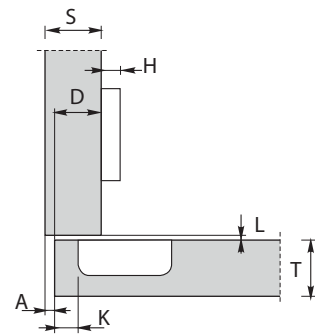

Half overlay C=9

Cod. C16B273



$$H = 3.5 + K - (D)$$

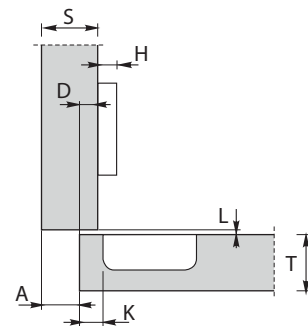

Inset C=17

Cod. C16C273



$$H = -4.5 + K + (A)$$

