

FOLDING SYSTEM

FOR 2 PANELS



Cod. DN-80PL2PTS

Installation guide

Unscaled format

2x **40 kg**
88 lbs

Max Door weight

12

Two doors

20 - 40 mm
51/64" - 1" 9/16

Wood Thickness

34
39

Track U21 ST

33
33

Carrier track U100

≤ 750

Doors width

COMPONENTS

A(x11) - #10x1"
 B(x12) - 3.5x15 (#6x5/8")
 C(x2) - #8x5/8"

ø9.0

HP=HV-80

HP=HV-75

HP=HV-74

HP=HV-69

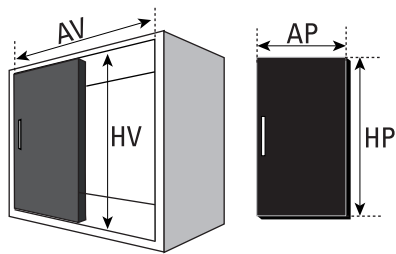

e	F
20/22/25	6
30/33	8
35/38	10
40	12

$AP = (AV - F) / 2$

mm	Decimal inches	Aprox Fraction	mm	Decimal inches	Aprox Fraction
1	0.0394	3/64	6	0.2362	15/64
2	0.0787	5/64	7	0.2756	9/32
3	0.1181	1/8	8	0.3150	5/16
4	0.1575	5/32	9	0.3543	23/64
5	0.1969	13/64	10	0.3937	25/64

All measurements in millimeters.

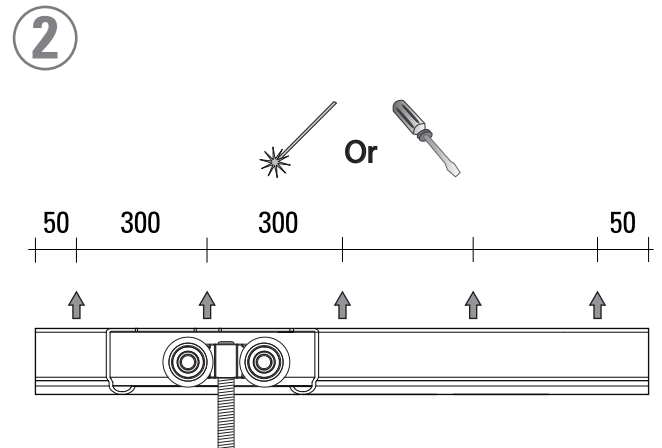
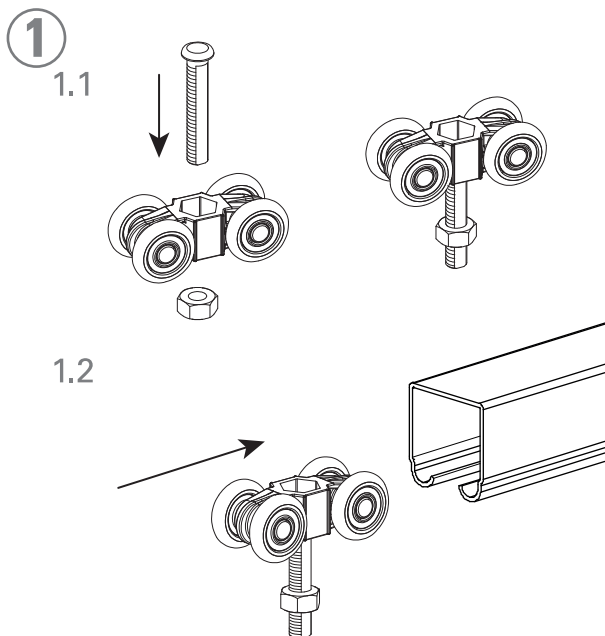

3

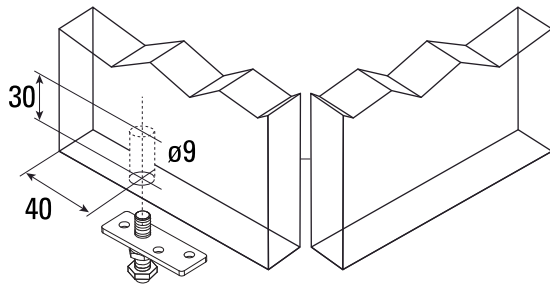
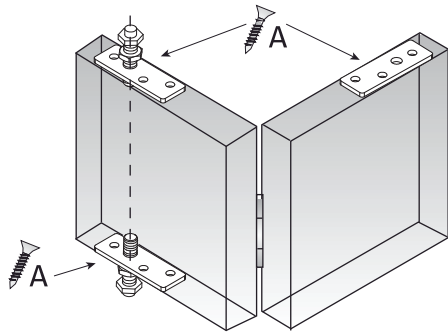
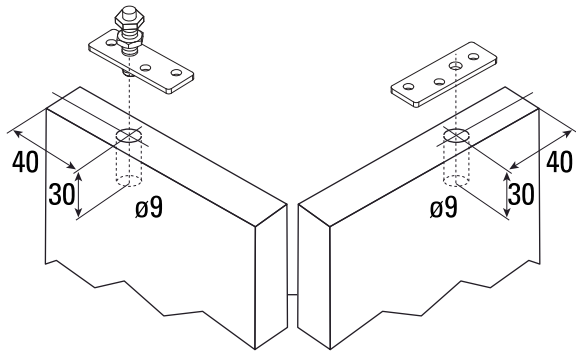

3

3.1

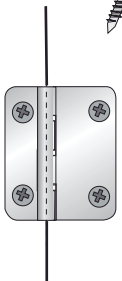

X1 = HP/2
X2 = HP/6

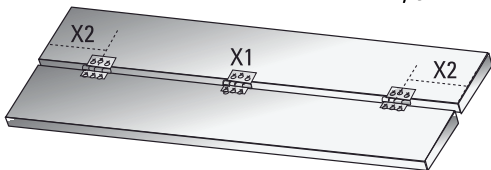

3.2

e	D
20/22/25	42
30/33	43
35/38	44
40	45

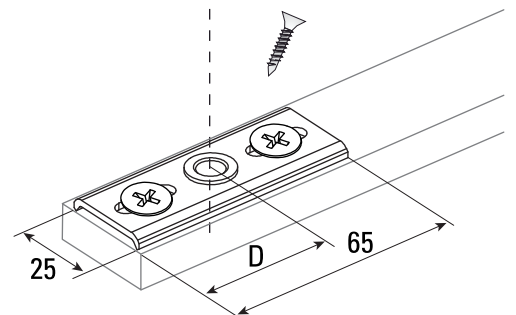
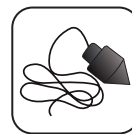
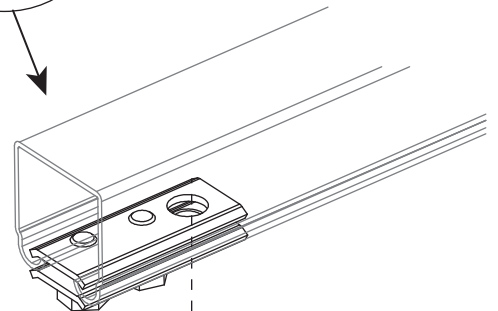
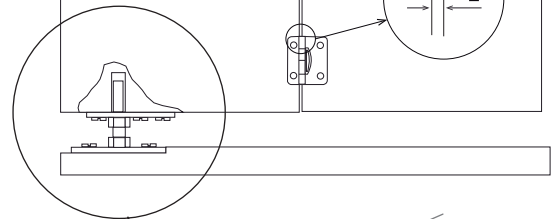
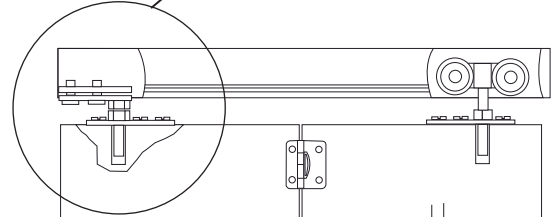
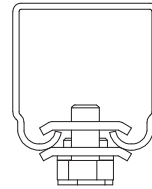
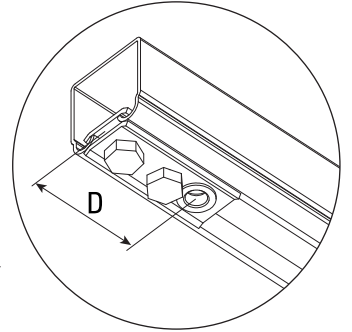
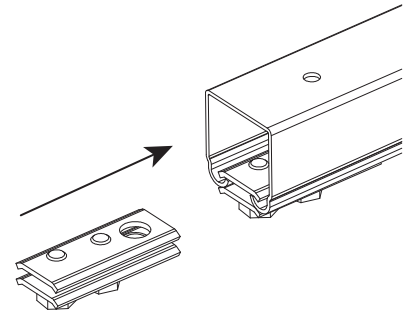

3.3

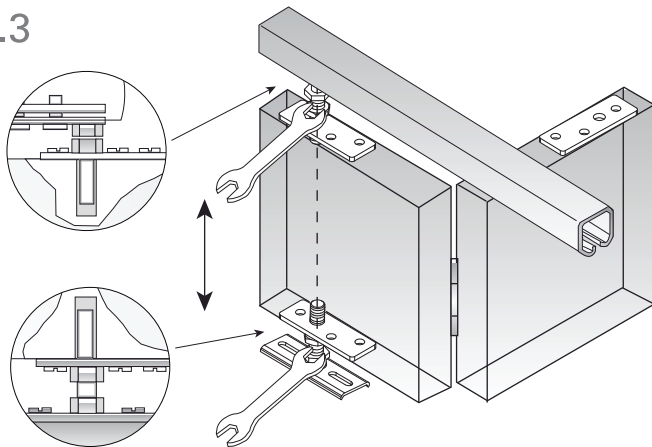

3.4

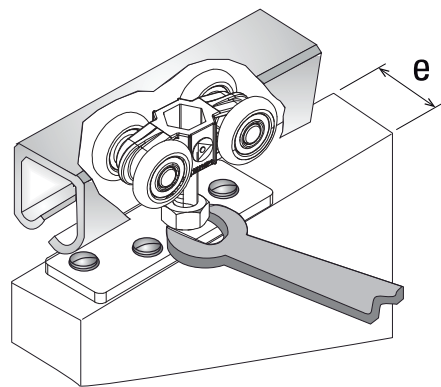

3.5

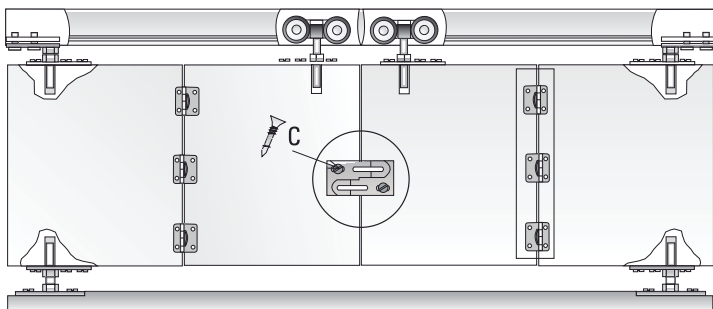

3.6

