

SLIDING DOOR SYSTEMS

SOFT-CLOSE SLIDING SYSTEM 264 LBS



Cod. JM960AX2-120

Installation Guide

1. Sliding system with double side soft closing function, for 264 Lbs wood door
2. Function: Double side softclosing, height adjustable.
3. Advantages: Easy installation, smooth operation, stable performance and long service life.
4. Material: Zinc alloy body + PSF roller
5. Specification:

Item		Specification
1	Door weight	110kg-120kg
2	Door thickness	≥30mm
3	Door width	≥730mm
4	Height adjustable range	±2.5mm
5	Softclosing distance	75mm
6	Noise decibel	≤35dB
7	Product life	≤ 100,000 cycles

6. Application:
For wood door or metal frame glass door.
Apply to residence, hotel, office, etc.

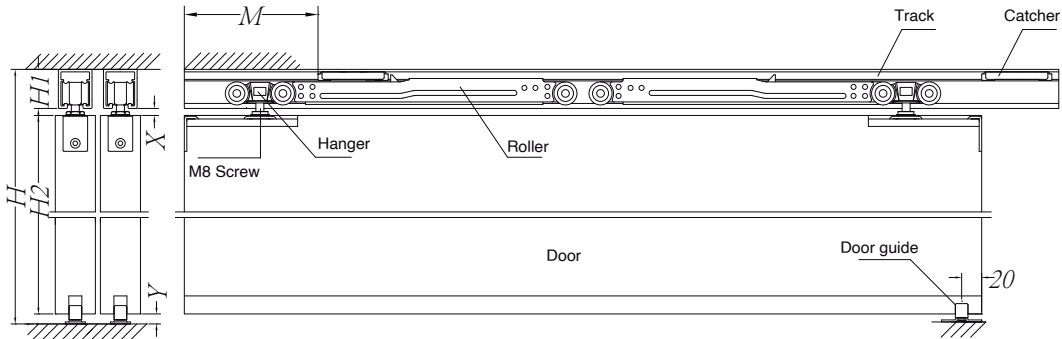

7. Dimension calculation:

Door height:

120KG Softclosing roller			
Door Height formula	Track Height H1	Upper door gap X	Bottom door gap Y
$H2=H-H1-X-Y$	H1=39mm	X=15mm	Y=8mm

Slotting for door guide:

Processing item	Door guide drawing	Slotting dimensions	Remark
Slotting for door guide			The groove must be smooth

Remark:

Install the hanger 11mm away from the door edge, and M=140mm.