

SLIDING SYSTEM FOR CLOSET

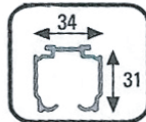

Unscaled format

Cod. DN-50CLIP Installation guide

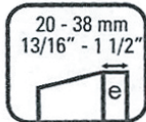

Carrier Track U45

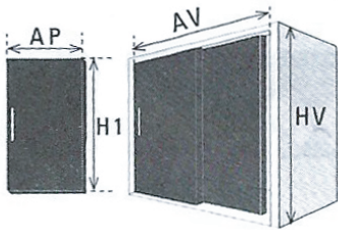

$$H1 = HV - 38\text{mm}$$

$$AP = AV/2 + 40\text{mm min.}$$

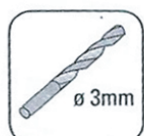
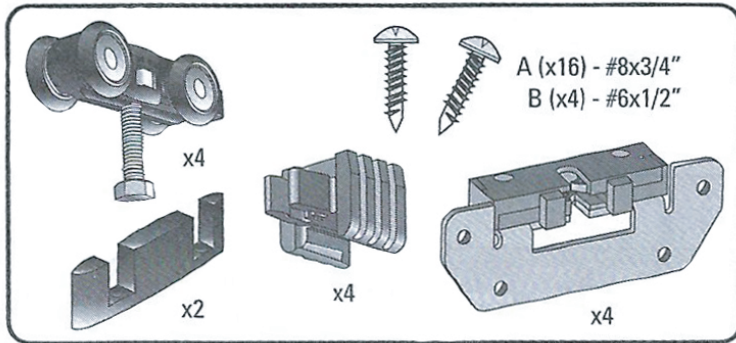

All measurements in millimeters.

mm	Decimal inches	Aprox Fraction	mm	Decimal inches	Aprox Fraction
1	0.0394	3/64	6	0.2362	15/64
2	0.0787	5/64	7	0.2756	9/32
3	0.1181	1/8	8	0.3150	5/16
4	0.1575	5/32	9	0.3543	23/64
5	0.1969	13/64	10	0.3937	25/64

1

1.1

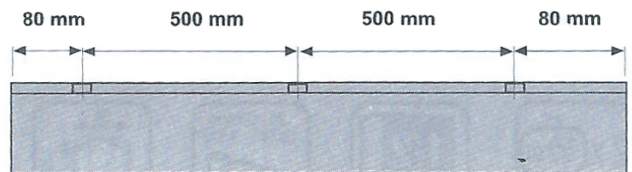

1.2

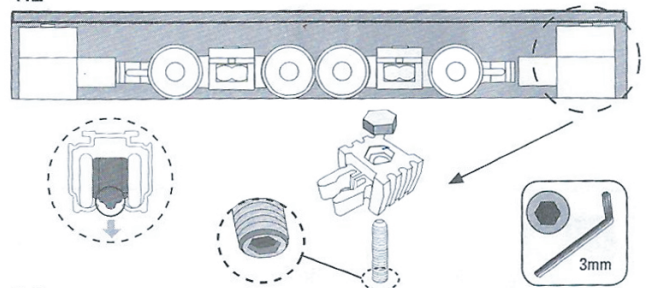

1.3

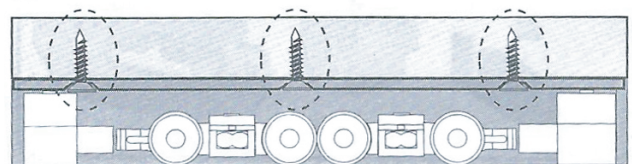

2

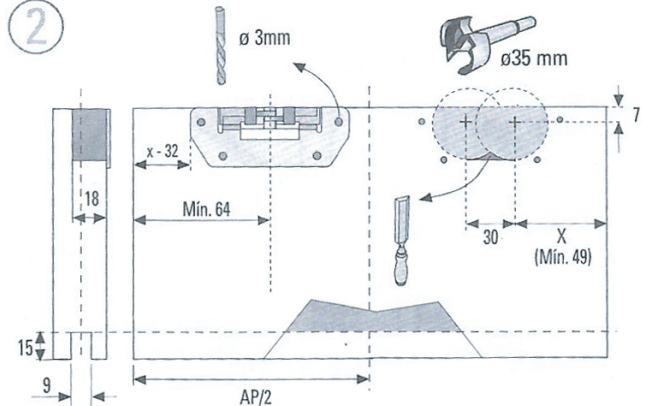

3

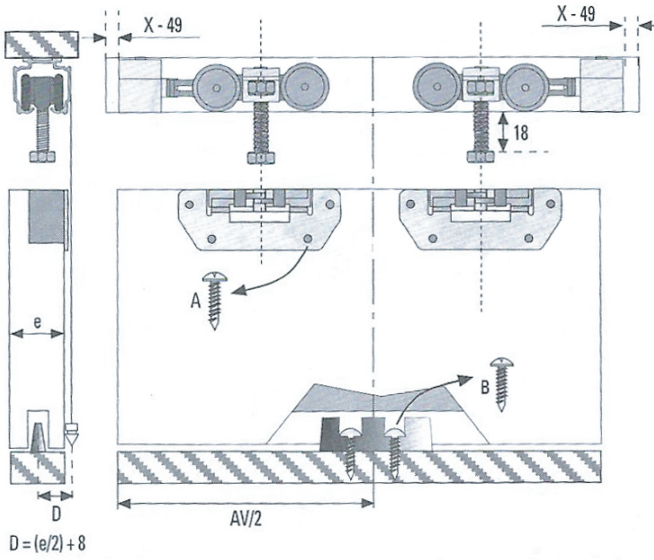

4

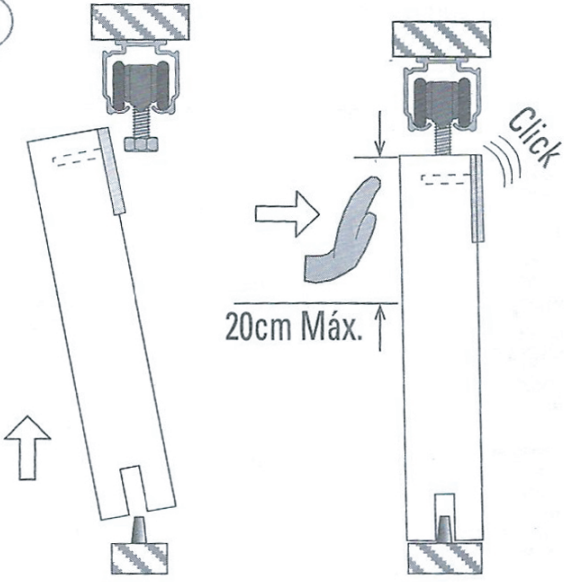

5

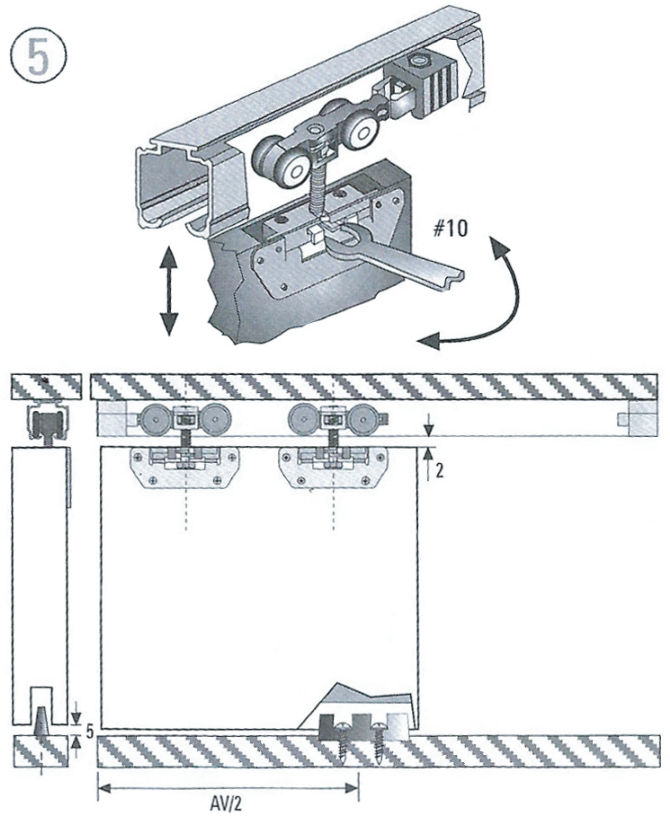

* ACCESORIES

