

# SLIDING SYSTEM FOR DOOR



## Cod. DN-50C/F Installation guide



Door weight



One door



Wood Thickness

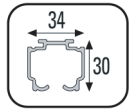

Track U45

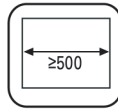

Minimum width

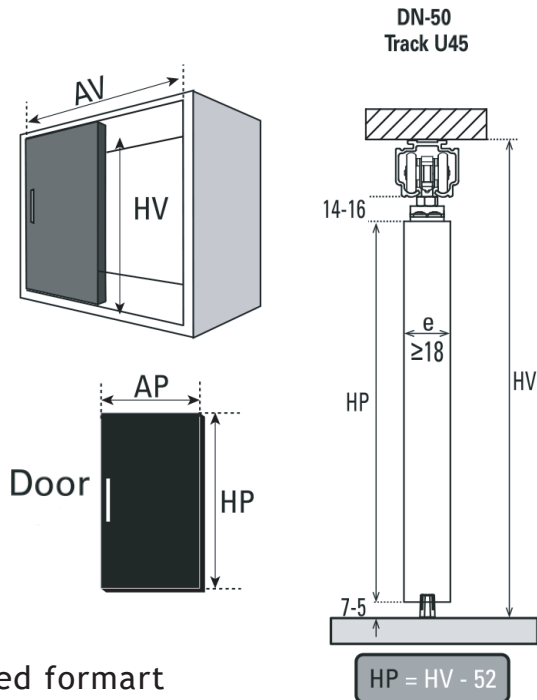
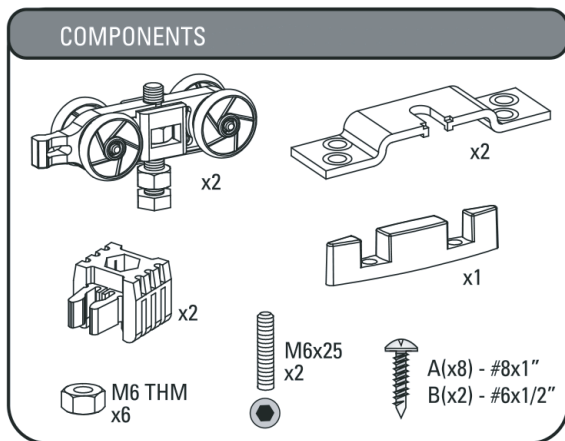

Unscaled format

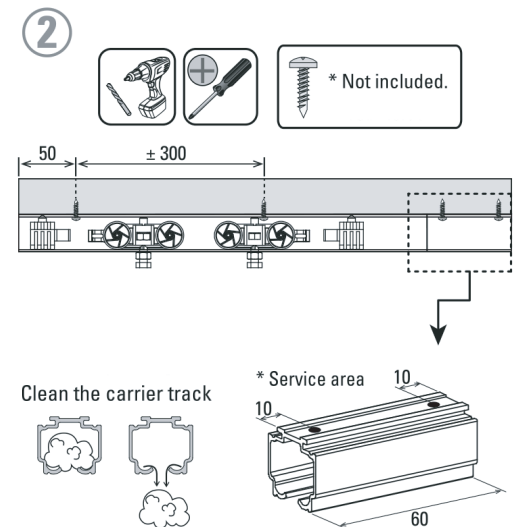
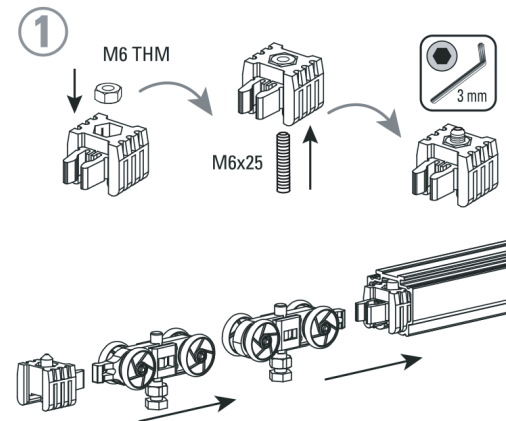
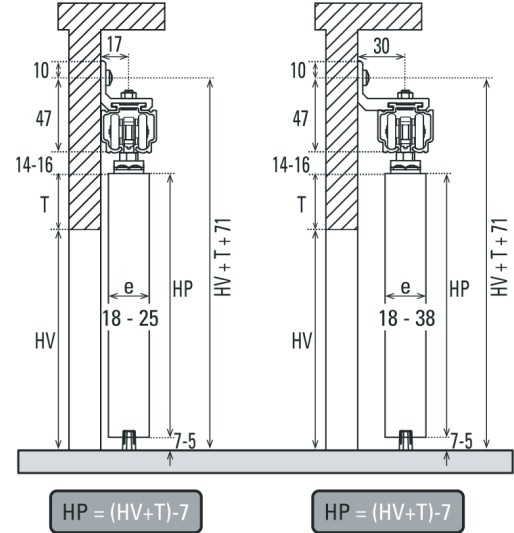

### 3 Fixed panel + door

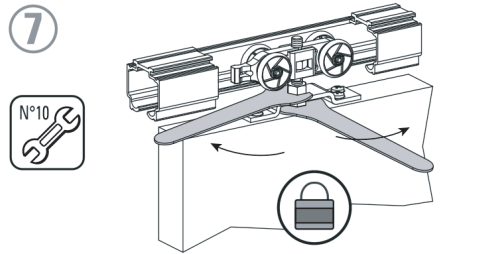
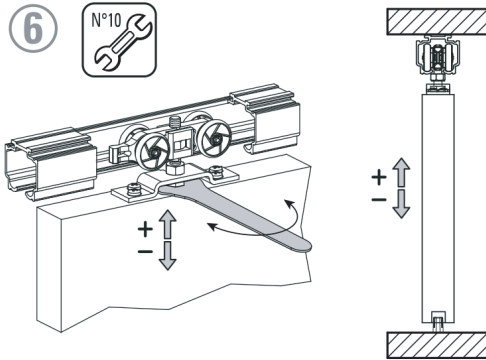
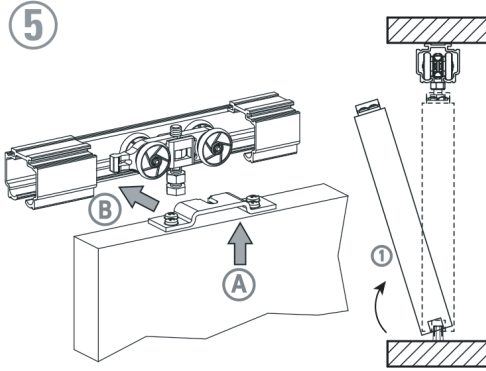
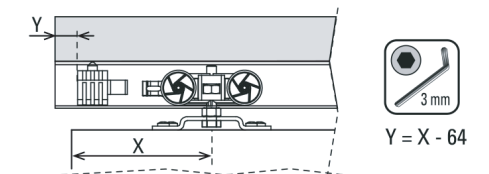
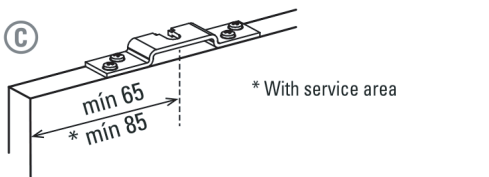
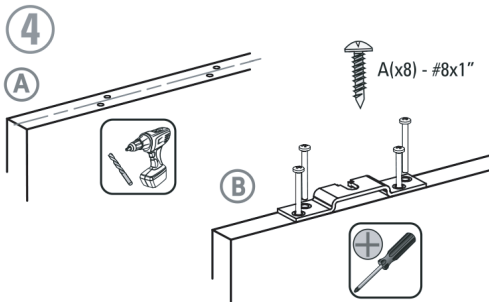
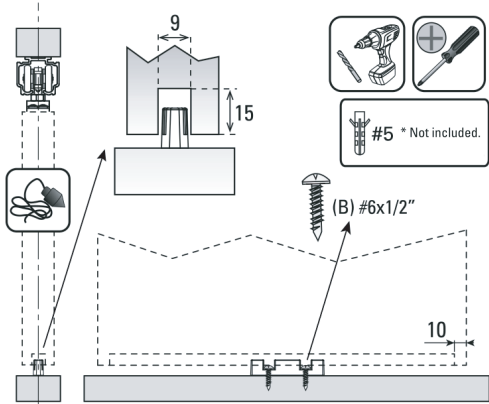
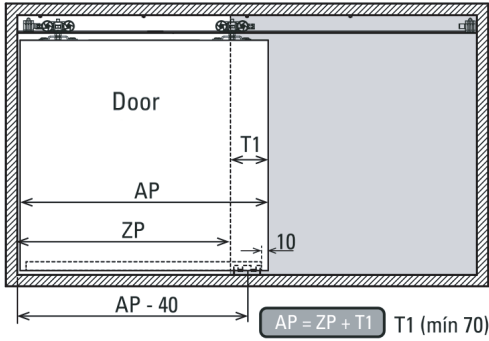

### \* ACCESORIES

Lateral bracket

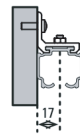

Lateral bracket wide

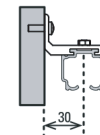

mm	Decimal inches	Aprox Fraction
1	0.0394	3/64
2	0.0787	5/64
3	0.1181	1/8
4	0.1575	5/32
5	0.1969	13/64

mm	Decimal inches	Aprox Fraction
6	0.2362	15/64
7	0.2756	9/32
8	0.3150	5/16
9	0.3543	23/64
10	0.3937	25/64

All measurements in millimeters.